

# Front VIEW

# Back VIEW

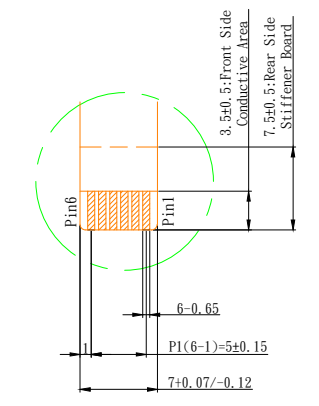
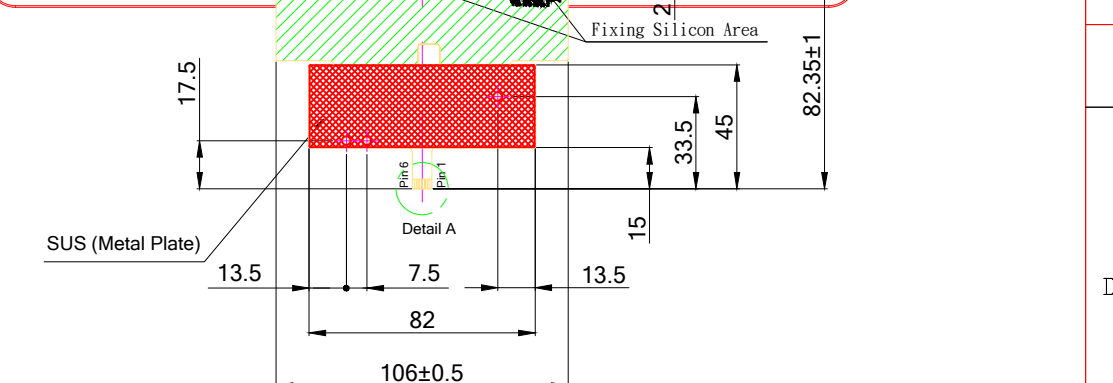
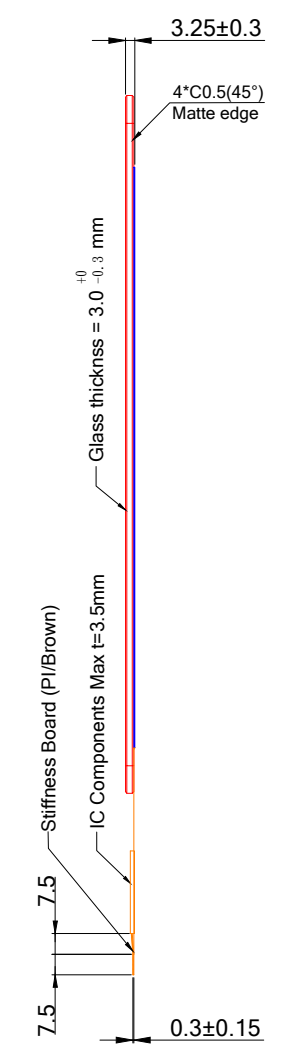
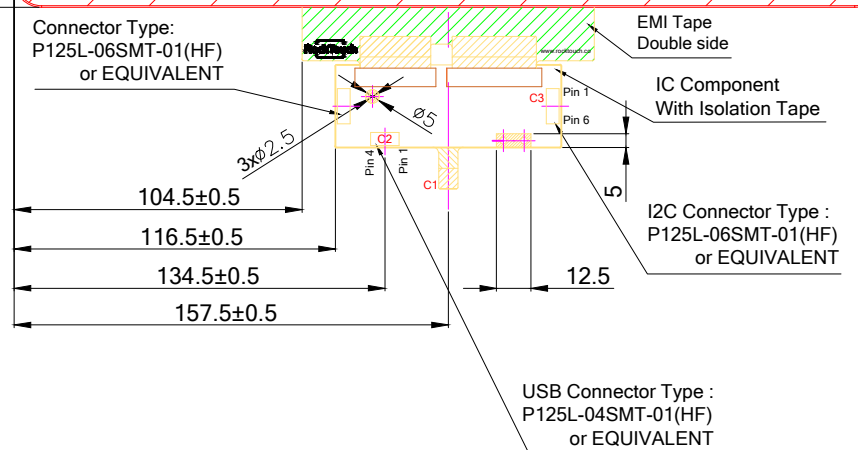
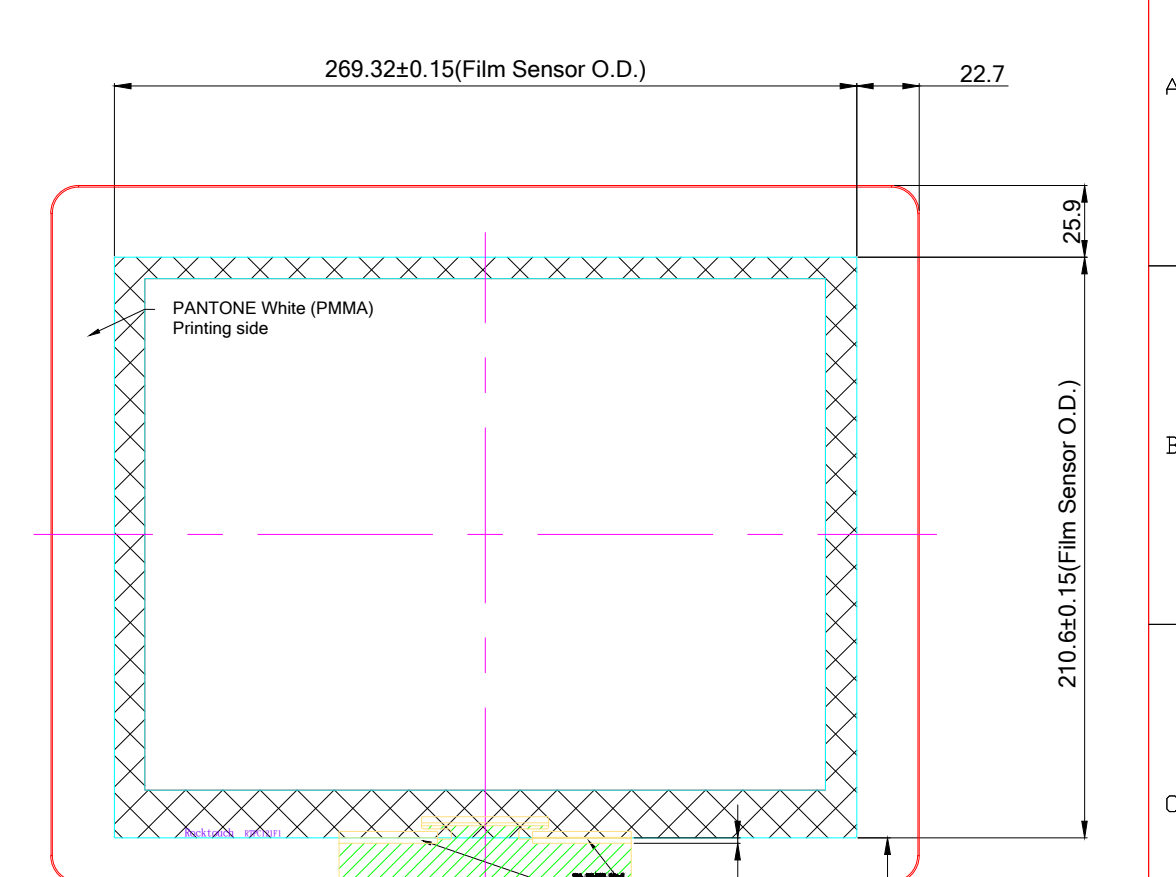
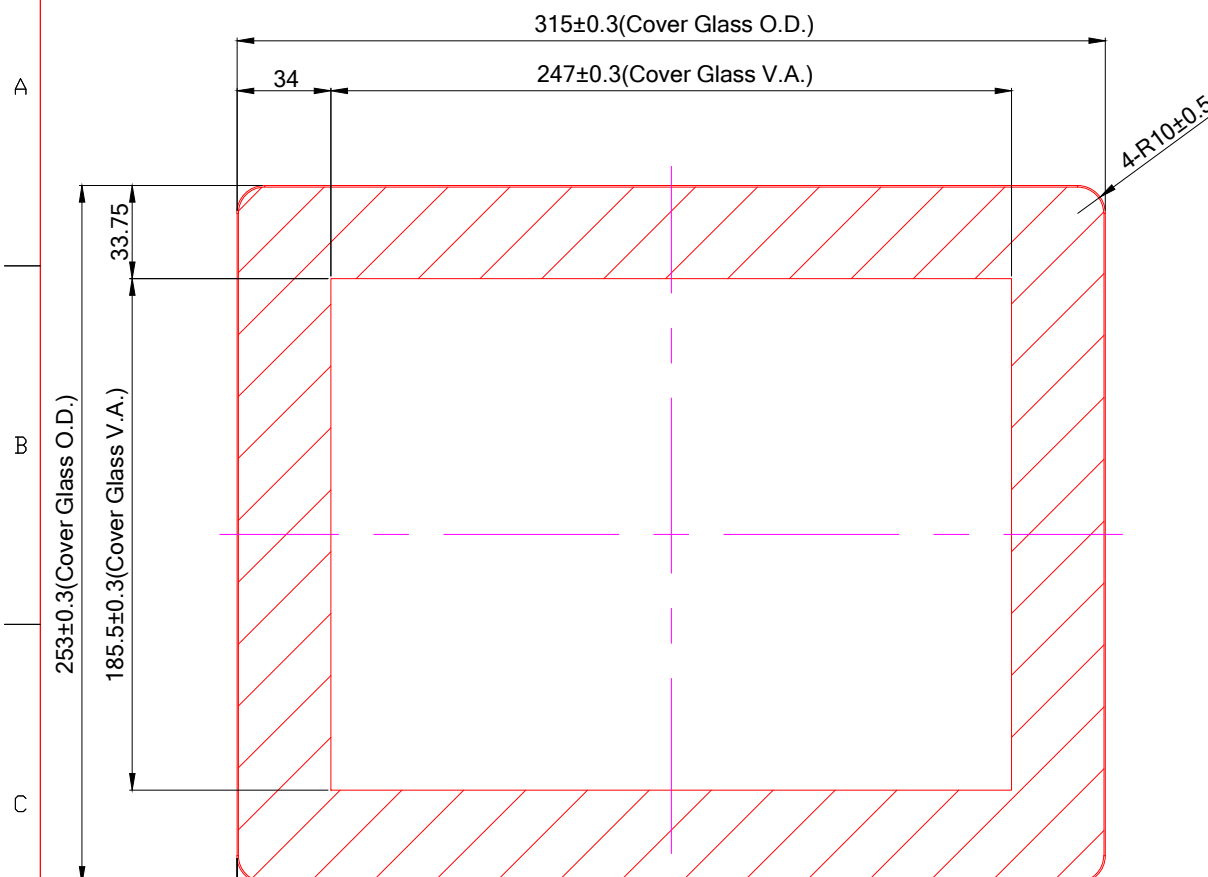

- Spec:
- 1. General O.D. Tolerance :  ±0.3
  - 2. Border Type :  Matte
  - 3. Glass Type :  Semi-Tempered
  - 4. Surface Treatment :  None
  - 5. Background Printing :  PMMA  Color 1 : Pantone White
  - 6. Logo Printing :  None
  - 7. Transmittance Level : >85%
  - 8. Important Notes :

- Note:
- A. Distance between LCD and Touch need to have minimum 1 mm otherwise thinner dimension can cause noise problem between LCD and touch screen
  - B. If customer put a front conductive bezel all around we need to have minimum thickness of 2mm, if the thickness is lower can cause interference
  - C. Refer to the integration guide to avoid any integration noise issue
  - D. Before mass production customer needs to ask custom firmware for his final machine

C1:USB Interface		C2: Pin Define for USB 4 pin		C3: Pin Define for I2C 6 pin	
Pin 01	GND	Pin 01	GND	Pin 01	GND
Pin 02	D-	Pin 02	D-	Pin 02	SDA
Pin 03	D+	Pin 03	D+	Pin 03	SCL
Pin 04	VDD(5V)	Pin 04	VDD	Pin 04	VDD(5V)
Pin 05	NC			Pin 05	INT
Pin 06	RST			Pin 06	RST

Customer Approval		Part Number		RTPC121F1-R1-30WP1-C	
Date	Rev.	Date	Person	Description	
Company					
Name					
Signature		Date	Design By	Date	Check By
		20190114	Jeff		
		Date	Design By	Date	Check By
		Date	Design By	Date	Check By

